

MB 同步螺杆升降机 MB SYNCHRONOUS SCREW LIFT

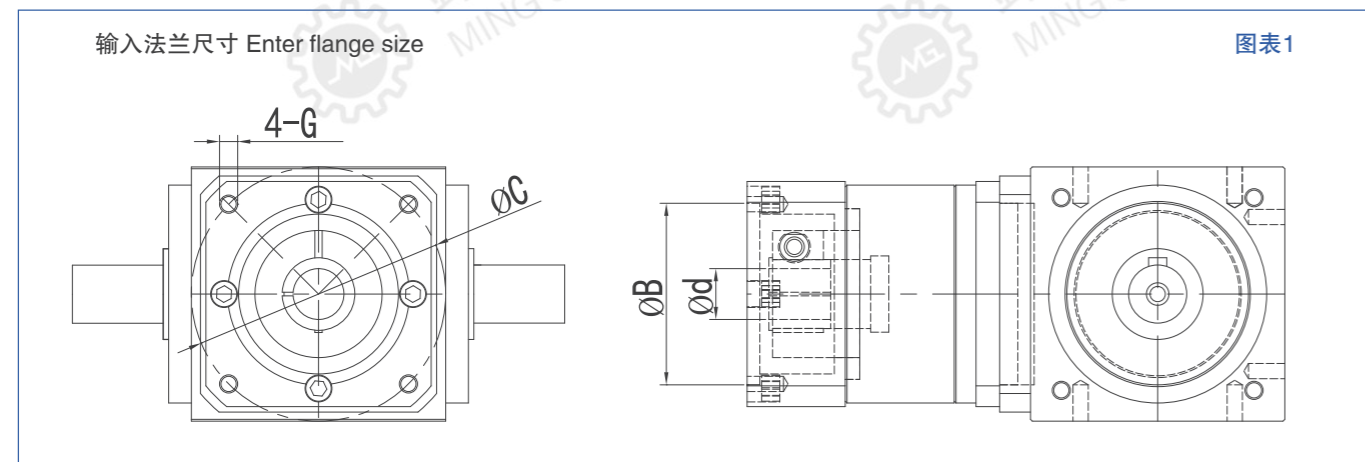

MB-G1-JDT单轴螺杆升降机电缸型式

MB-G1-JDT SINGLE SHAFT SCREW LIFTER ELECTRIC CYLINDER TYPE

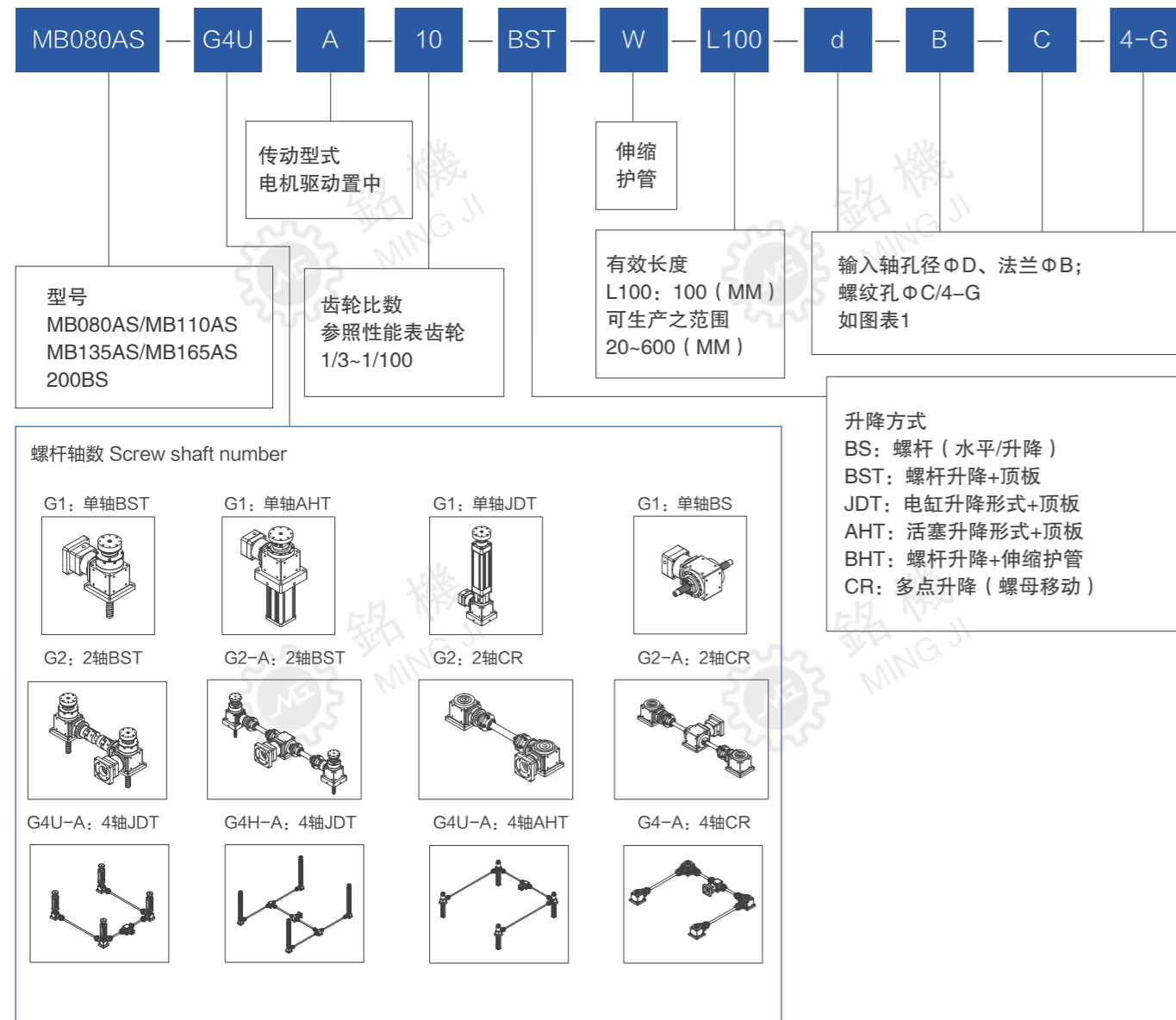
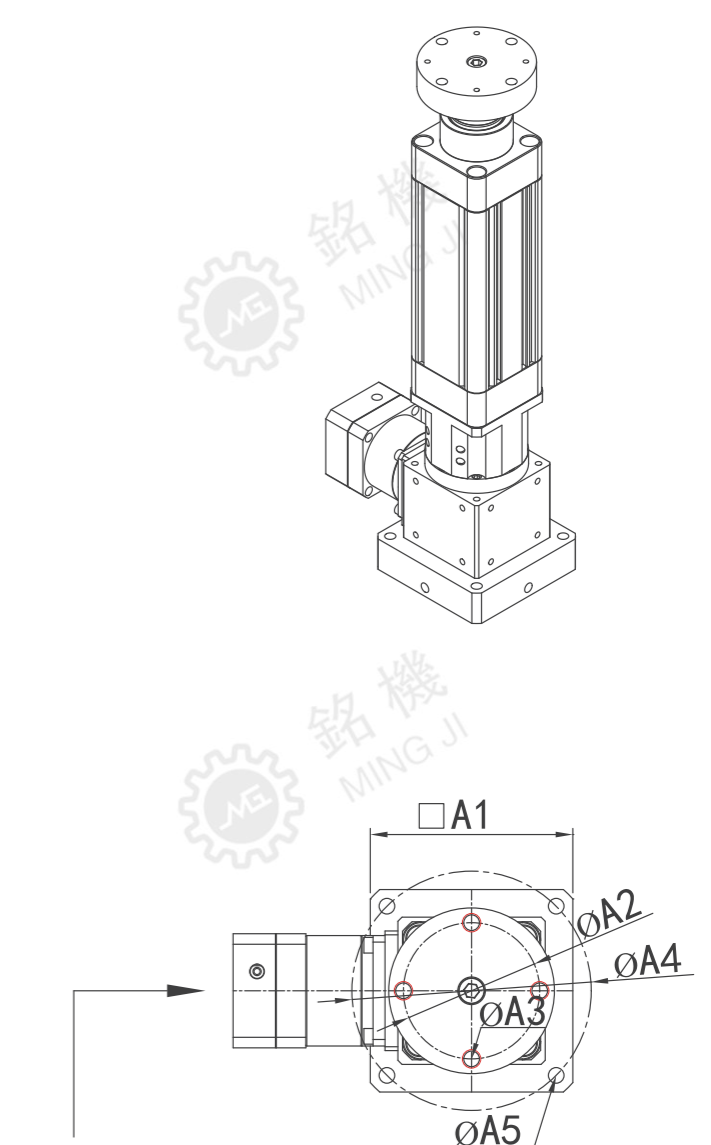
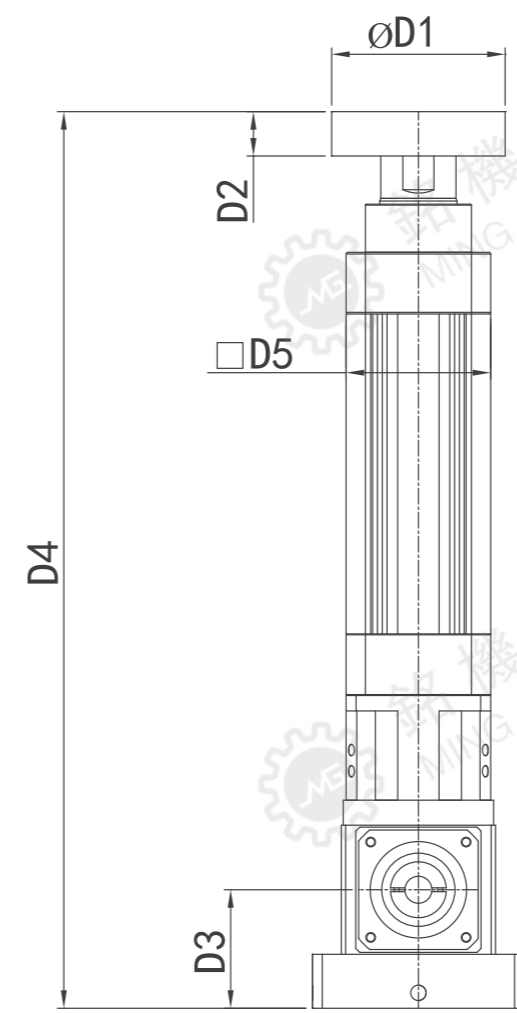

- P.S:电缸型(内含直线导轨)
- 1.滚珠螺杆直径(16/20/25/32)。
 - 2.滚珠螺杆导程(5/10/20/25/30/32)。
 - 3.正确尺寸依2D/3D为准。
- P.S: Electric cylinder type (including linear guide rail)
1. Ball screw diameter (16/20/25/32).
 2. Ball screw lead (5/10/20/25/30/32).
 3. The correct size is subject to 2D/3D.

输入端尺寸
(依选定电机而定)

Input size
(Depending on the selected motor)

规格表 Specifications

规格specification	D1	D2	D3	D4	D5	A1	A2	A3	A4	A5
MB080AS-G1-JDT75	90	23	61.5	依实际行程 (mm)	75	110	74	4-M10	130	4- ϕ 8.5
MB110AS-G1-JDT97	90	23	61.5/65		97	142	74	4-M10	170	4- ϕ 8.5

MB-G2-JDT 2轴螺杆升降机电缸型式

MB-G2-JDT 2-AXIS SCREW LIFT ELECTRIC CYLINDER TYPE

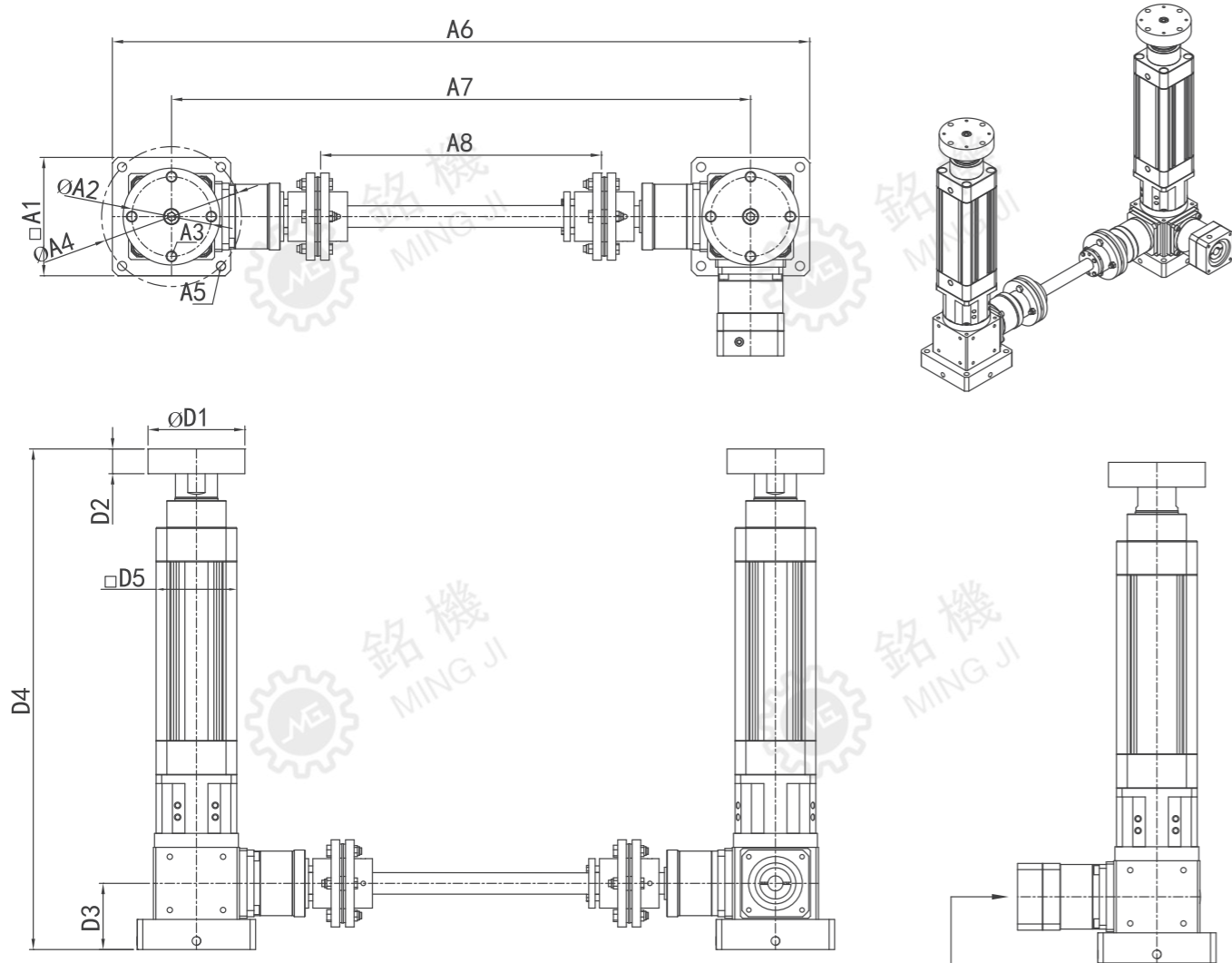

- P.S:电缸型(内含直线导轨)
 1.滚珠螺杆直径(16/20/25/32)。
 2.滚珠螺杆导程(5/10/20/25/30/32)。
 3.正确尺寸依2D/3D为准。

- P.S: Electric cylinder type (including linear guide rail)
 1. Ball screw diameter (16/20/25/32).
 2. Ball screw lead (5/10/20/25/30/32).
 3. The correct size is subject to 2D/3D.

输入端尺寸
(依选定电机而定)
 Input size
(Depending on the selected motor)

规格表 Specifications

规格specification	D1	D2	D3	D4	D5	A1	A2	A3	A4	A5	A6	A7	A8
MB080AS-G2-JDT75	90	23	61.5	依实际行程 (mm)	75	110	74	4-M10	130	4-φ8.5	*依螺杆跨距而定		
MB110AS-G2-JDT97	90	23	61.5/65		97	142	74	4-M10	170	4-φ8.5			

MB-G4U-A-JDT4轴螺杆升降机电缸型式

MB-G4U-A-JDT 4-AXIS SCREW LIFTER ELECTRIC CYLINDER TYPE

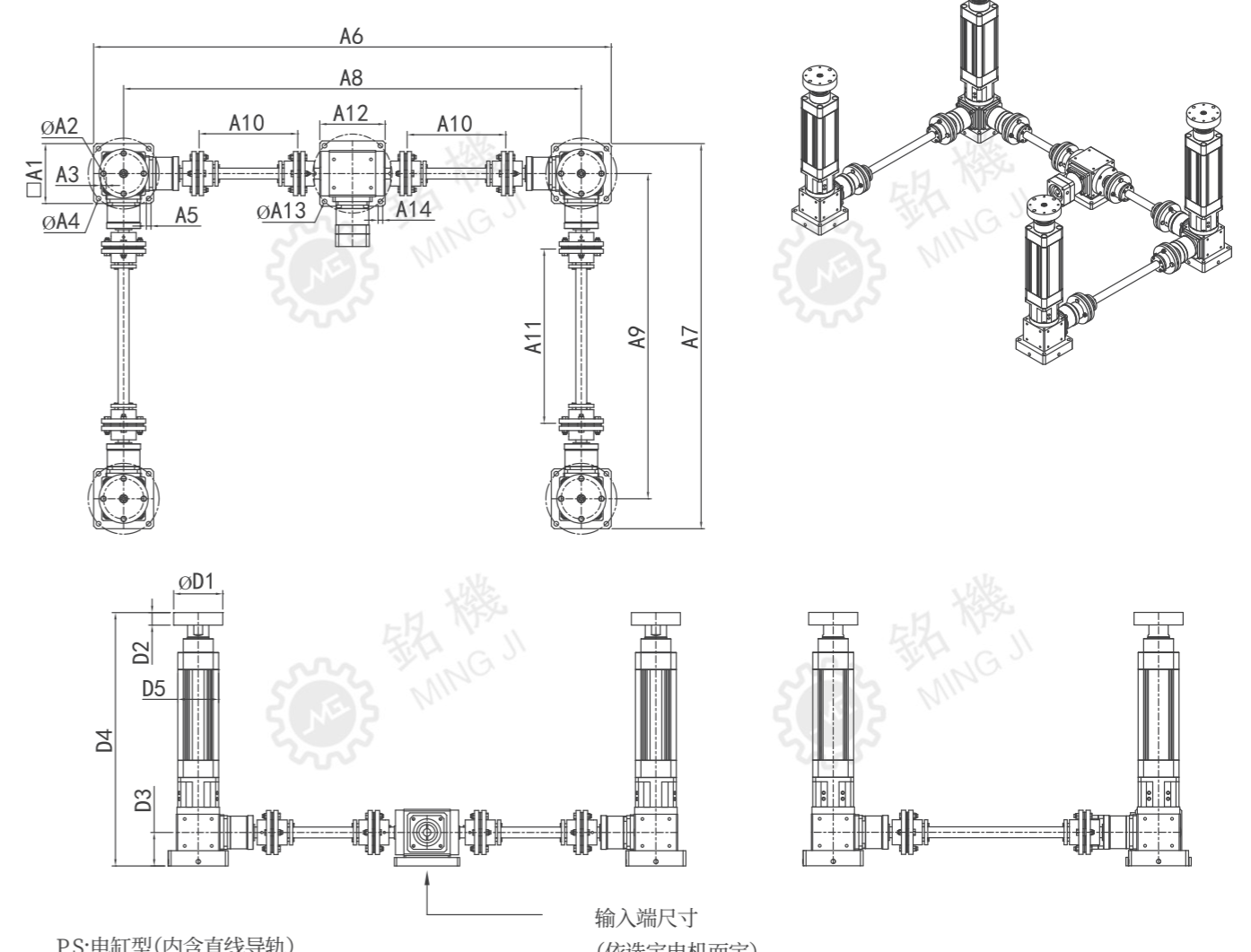

- P.S:电缸型(内含直线导轨)
 1.滚珠螺杆直径(16/20/25/32)。
 2.滚珠螺杆导程(5/10/20/25/30/32)。
 3.正确尺寸依2D/3D为准。

- P.S: Electric cylinder type (including linear guide rail)
 1. Ball screw diameter (16/20/25/32).
 2. Ball screw lead (5/10/20/25/30/32).
 3. The correct size is subject to 2D/3D.

输入端尺寸
(依选定电机而定)
 Input size
(Depending on the selected motor)

规格表 Specifications

规格specification	D1	D2	D3	D4	D5	A1	A2	A3	A4	A5	A6	A7	A8
MB080AS-G2-JDT75	90	23	61.5	依实际行程 (mm)	75	110	74	4-M10	130	4-φ8.5	*依螺杆跨距而定		
MB110AS-G2-JDT97	90	23	61.5/65		97	142	74	4-M10	170	4-φ8.5			

规格specification	D9	D10	D11	D12	D13	D14
MB080AS-G2-JDT75	*依螺杆跨距而定			120	145	4-φ8.5
MB110AS-G2-JDT97				42	170	4-φ8.5

MB-G1-AHT 单轴螺杆升降机活塞型式

MB-G1-AHT SINGLE SHAFT SCREW ELEVATOR PISTON TYPE

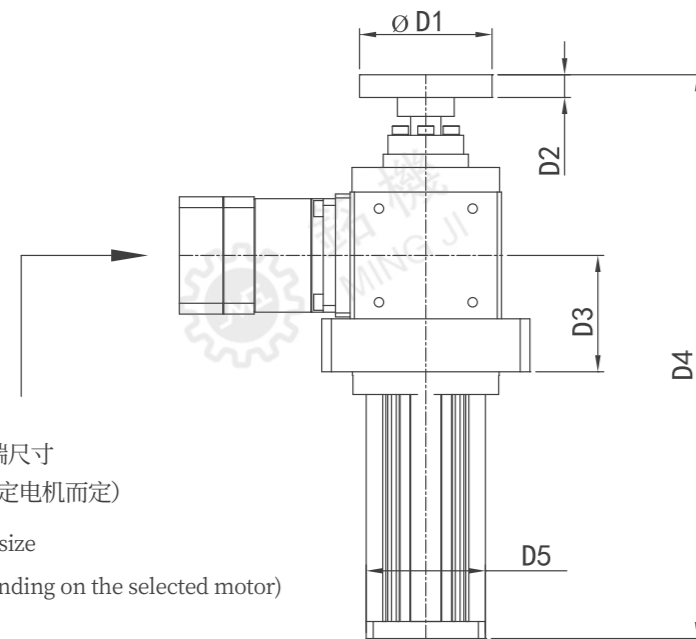
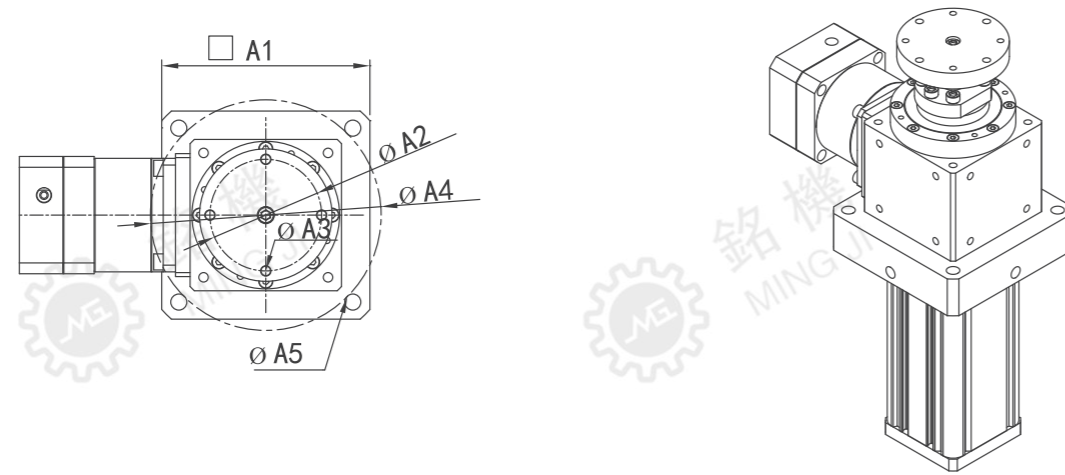

输入端尺寸
(依选定电机而定)
Input size
(Depending on the selected motor)

P.S:活塞型(内含直线导轨)
1.滚珠螺杆直径(16/20/25)。
2.滚珠螺杆导程(5/10/20/25)。
3.正确尺寸依2D/3D为准。

P.S: Piston type (including linear guide)
1. Ball screw diameter (16/20/25).
2. Ball screw lead (5/10/20/25).
3. The correct size is subject to 2D/3D.

规格表 Specifications

规格specification	D1	D2	D3	D4	D5	A1	A2	A3	A4	A5
MB080AS-G1-AHT	70	12	61.5	依实际行程 (mm)	63	110	59	4-M6	130	4-φ8.5
MB110AS-G1-AHT	90	23	61.5/65		75	142	74	4-M10	170	4-φ8.5

MB-G2-AHT 2轴螺杆升降机活塞型式

MB-G2-AHT 2-AXIS SCREW ELEVATOR PISTON TYPE

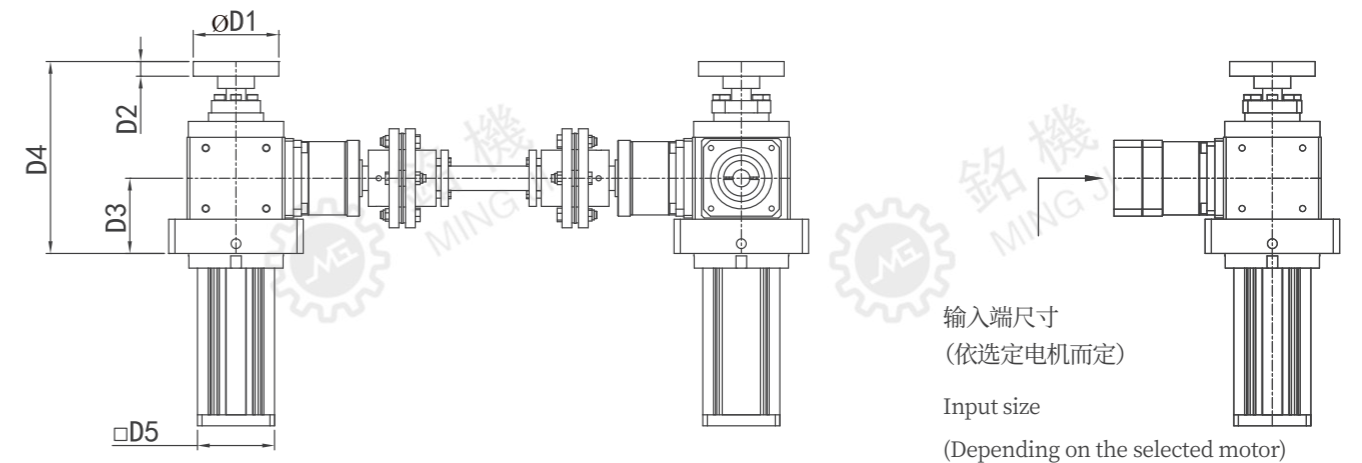
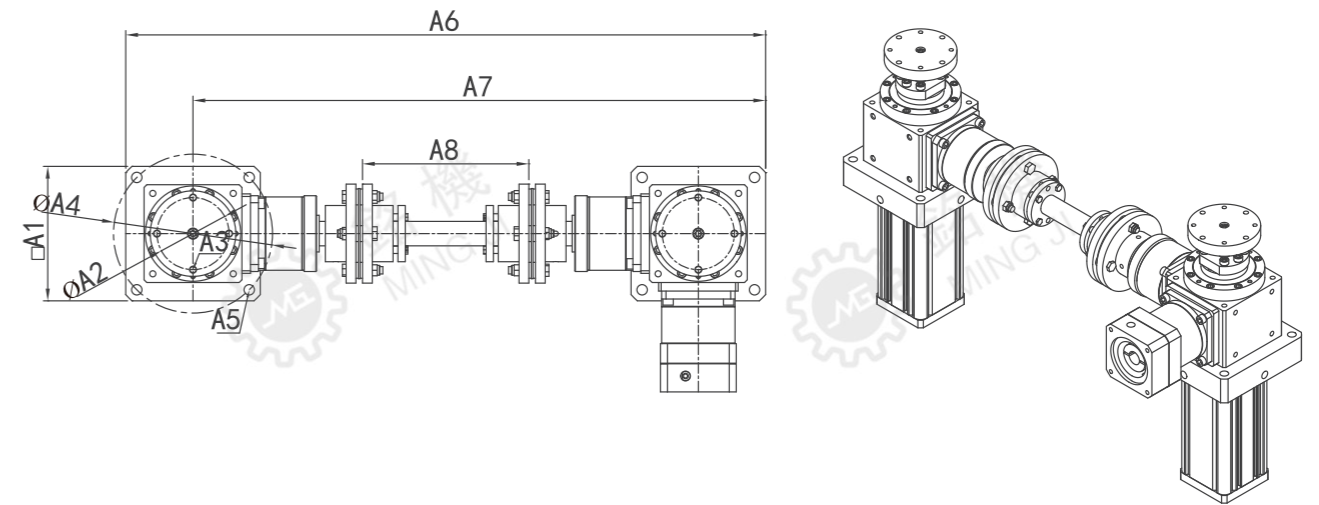

输入端尺寸
(依选定电机而定)
Input size
(Depending on the selected motor)

P.S:活塞型(内含直线导轨)
1.滚珠螺杆直径(16/20/25)。
2.滚珠螺杆导程(5/10/20/25)。
3.正确尺寸依2D/3D为准。

P.S: Piston type (including linear guide)
1. Ball screw diameter (16/20/25).
2. Ball screw lead (5/10/20/25).
3. The correct size is subject to 2D/3D.

规格表 Specifications

规格specification	D1	D2	D3	D4	D5	A1	A2	A3	A4	A5	A6	A7	A8
MB080AS-G2-AHT	70	12	61.5	依实际行程 (mm)	63	110	59	4-M6	130	4-φ8.5	*依螺杆跨距而定		
MB110AS-G2-AHT	90	23	61.5/65		75	142	74	4-M10	170	4-φ8.5			

MB-G4U-AHT 4轴螺杆升降机活塞型式

MB-G4U-AHT 4-AXIS SCREW LIFT PISTON TYPE

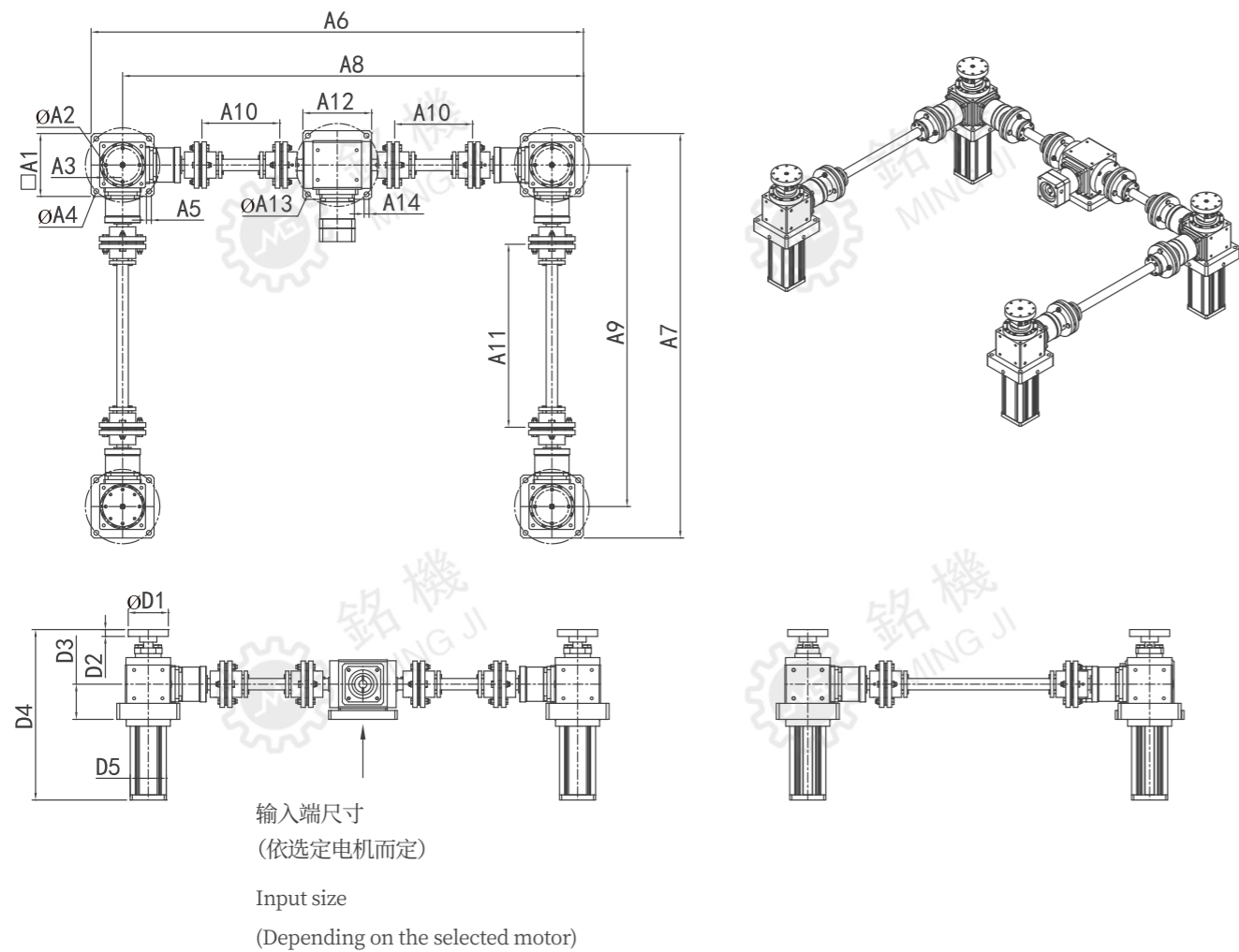

P.S:活塞型(内含直线导轨)

- 1.滚珠螺杆直径(16/20/25)。
- 2.滚珠螺杆导程(5/10/20/25)。
- 3.正确尺寸依2D/3D为准。

P.S: Piston type (including linear guide)

1. Ball screw diameter (16/20/25)。
2. Ball screw lead (5/10/20/25)。
3. The correct size is subject to 2D/3D.

规格表 Specifications

规格specification	D1	D2	D3	D4	D5	A1	A2	A3	A4	A5	A6	A7	A8
MB080AS-G4U-AHT	70	12	61.5	依实际行程 (mm)	63	110	59	4-M6	130	4-φ8.5	*依螺杆跨距而定		
MB110AS-G4U-AHT	90	23	61.5/65		75	142	74	4-M10	170	4-φ8.5			

规格specification	D9	D10	D11	D12	D13	D14
MB080AS-G4U-AHT	*依螺杆跨距而定			120	145	4-φ8.5
MB110AS-G4U-AHT				42	170	4-φ8.5

MB-BS 单轴螺杆减速机型式

MB-BS SINGLE SHAFT SCREW REDUCER TYPE

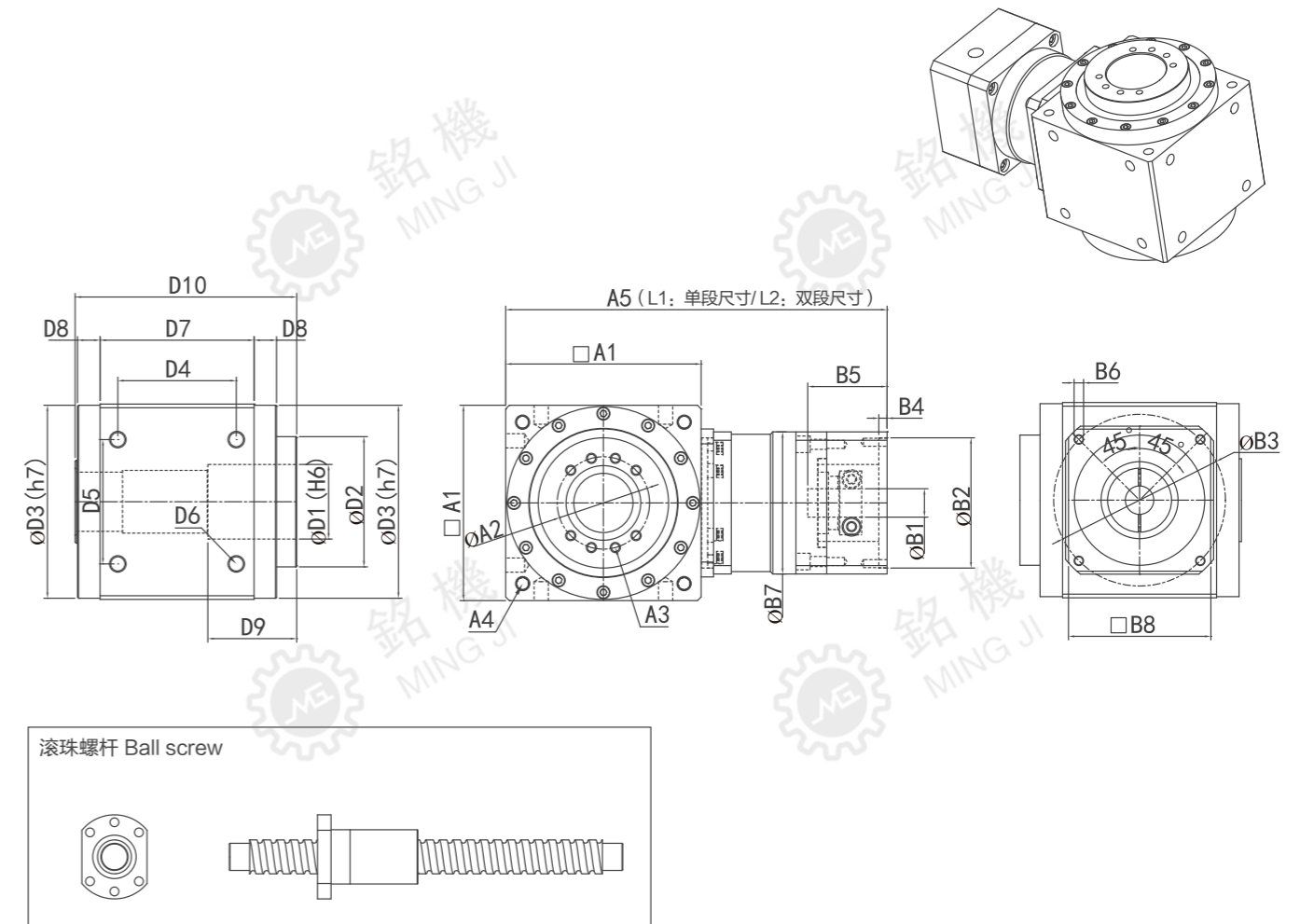

P.S:中空轴配合各厂牌滚珠螺杆

- 1.滚珠螺杆直径(16/20/25/32/40/50)。
- 2.滚珠螺杆导程(5/10/20/25/30/32/40/50)。
- 3.正确尺寸依2D/3D为准。

P.S: Hollow shaft to match ball screws of various brands

1. Ball screw diameter (16/20/25/32/40/50)。
2. Ball screw lead (5/10/20/25/30/32/40/50)。
3. The correct size is subject to 2D/3D.

规格表 Specifications

规格specification	D1	D2	D3	D4	D5	D6	D7	D8	D9	D10	A1	A2	A3	A2	A3
MTX080AS	28/36	45	78	49.5	49.5	4-M6	67	13	*依螺杆之 螺母尺寸 而定	80	*依螺杆之 螺母尺寸 而定	4-M6	*依选 定之电 机而定		
MTX110AS	40	65	106	68	65	4-M8	90	15						4-M8	
MTX135BS	50	85	133	78	83	4-M10	102	19						4-M10	
MTX165BS	63	110	163	100	105	4-M14	130	19						4-M12	
MTX200BS	75	140	195	129	130	4-M14	155	22						4-M16	

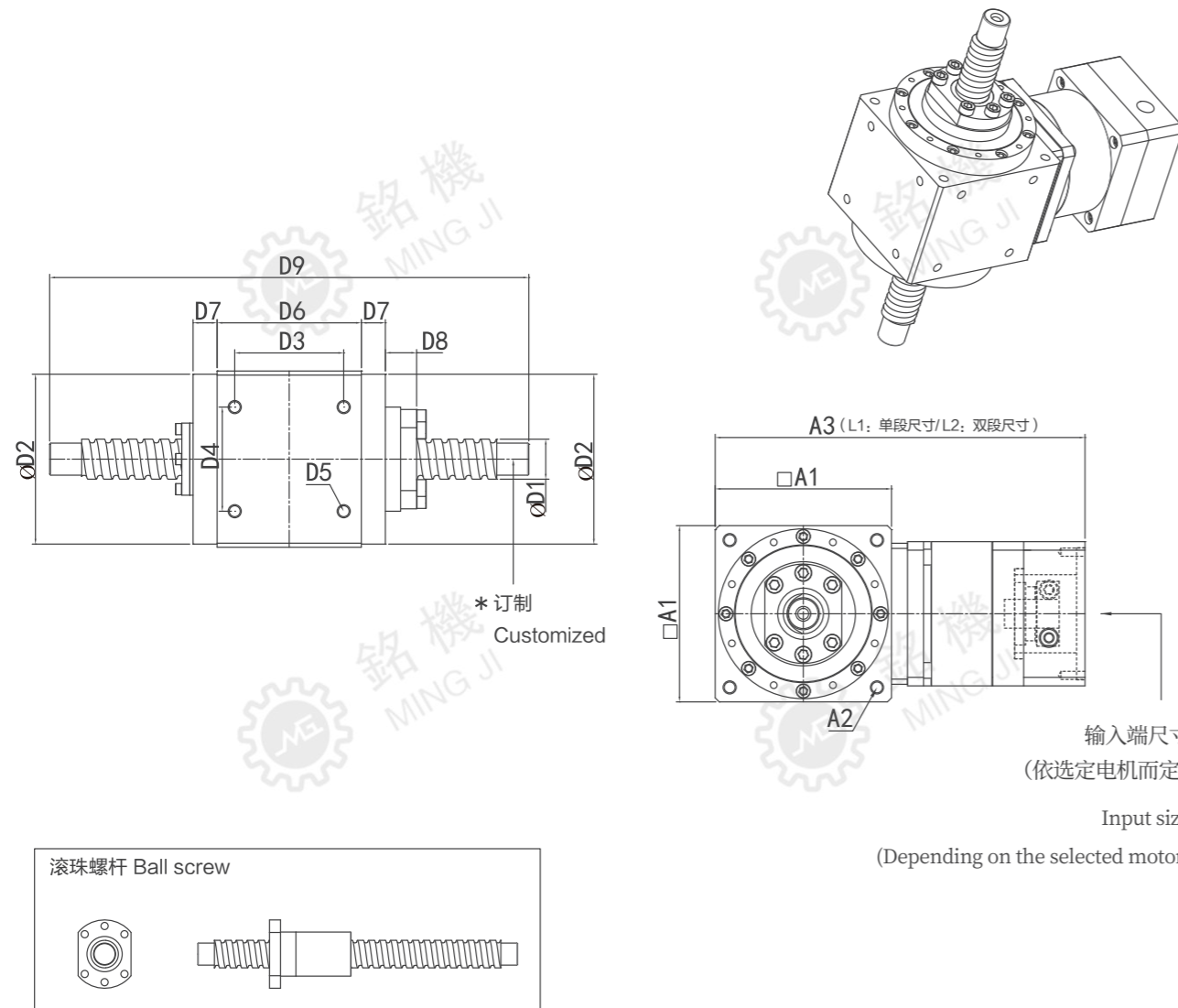
MB-BS 单轴螺杆减速机型式
MB-BS SINGLE SHAFT SCREW REDUCER TYPE

规格表 Specifications

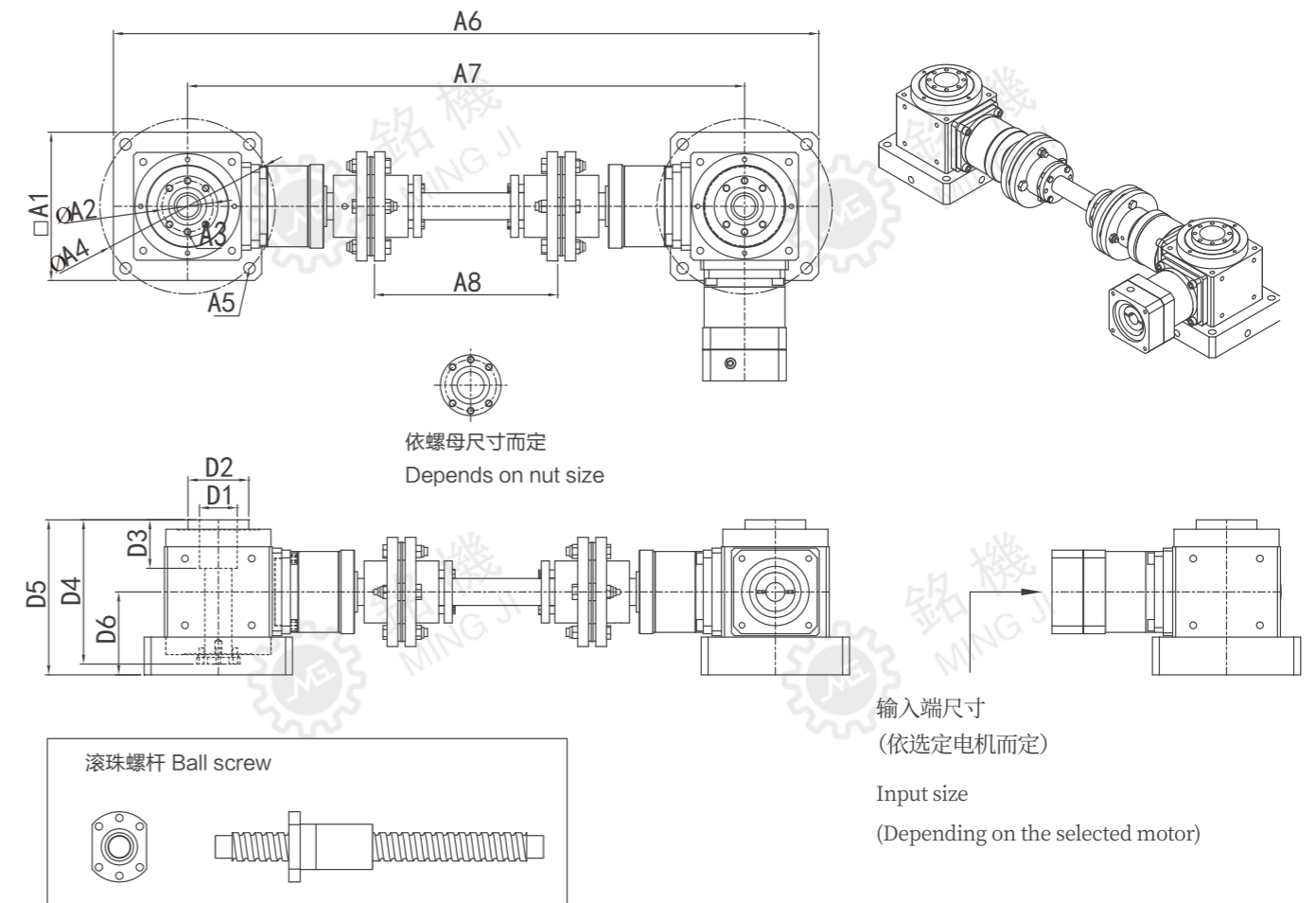
规格specification	D1	D2	D3	D4	D5	D6	D7	D8	D9	A1	A2	输入端轴/法兰 Input shaft/flange
MTX080AS	16/20	78	49.5	49.5	4-M6	67	13	*依选定之螺 杆尺寸而定		80	4-M6	*依选定之 电机而定
MTX110AS	25	106	68	65	4-M8	90	15		110	4-M8		
MTX135BS	32	133	78	83	4-M10	102	19		135	4-M10		
MTX165BS	40	163	100	105	4-M14	130	19		165	4-M12		
MTX200BS	50	195	129	130	4-M14	155	22		200	4-M16		

MB-G2-BS 螺杆升降机
MB-G2-BS SCREW LIFT

P.S: (2轴配升降机-配合各种厂牌螺杆)

1. 滚珠螺杆直径 (16/20/25)。
2. 滚珠螺杆导程 (5/10/20/25)。
3. 正确尺寸依2D/3D为准。

P.S: (2-axis with elevator-with various brand screws)

1. Ball screw diameter (16/20/25).
2. Ball screw lead (5/10/20/25).
3. The correct size is subject to 2D/3D.

规格表 Specifications

规格specification	D1(H6)	D2	D3	D4	D5	D6	A1	A2	A3	A4	A5	A6	A7	A8
MB080AS-G2	28/36	45	*依螺杆之尺寸而定			61.5	110			130	4-φ8.5	*依客户选定之跨距 而定		
MB110AS-G2	40	65		61.5/65	142	170	4-φ8.5							

MB-G4U-A-BS 螺杆升降机

MB-G4U-A-BS SCREW LIFT

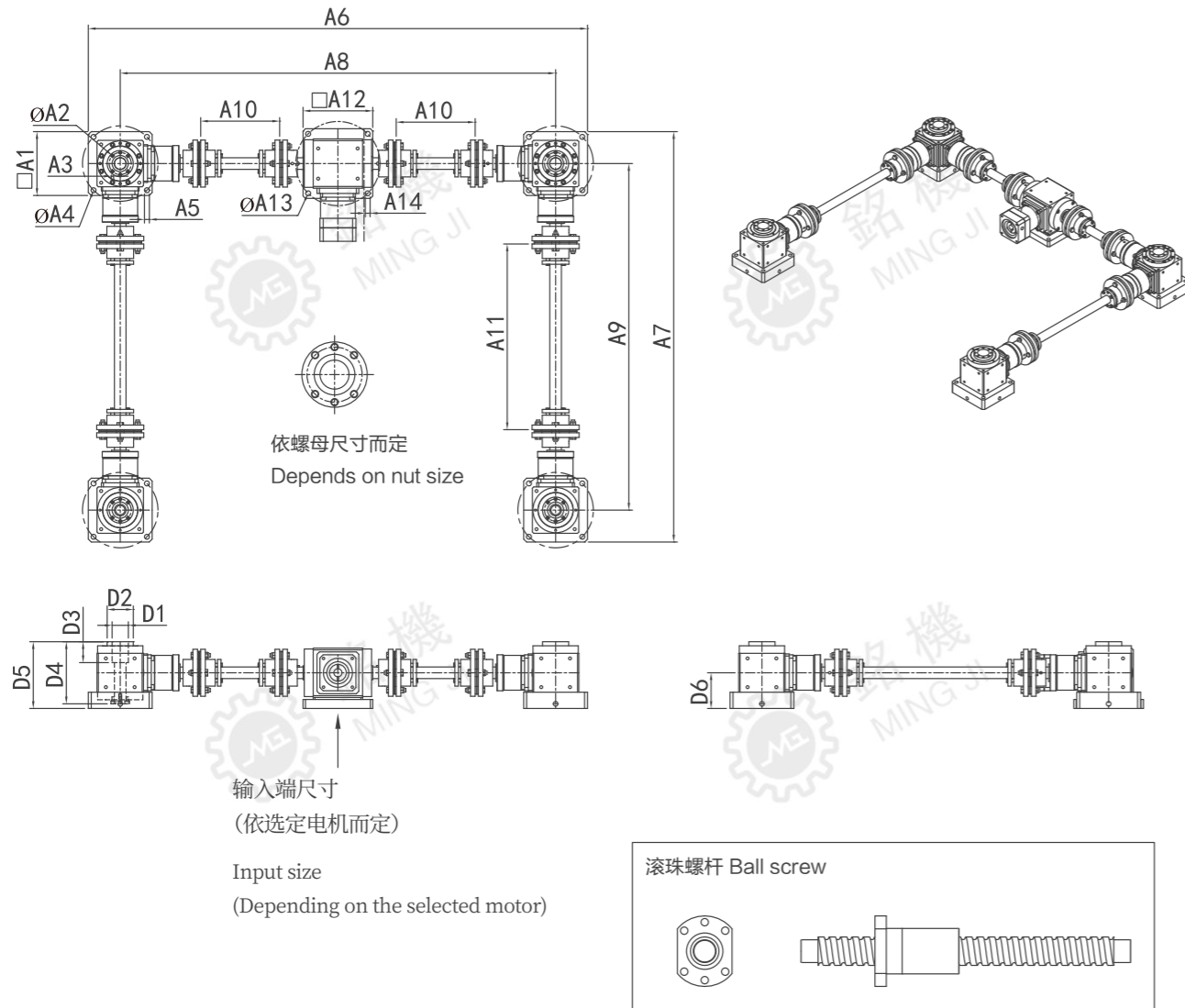

P.S: (4轴螺杆升降机-配合各种厂牌螺杆)

1. 滚珠螺杆直径(16/20/25)。
2. 滚珠螺杆导程(5/10/20/25)。
3. 正确尺寸依2D/3D为准。

P.S: (4-axis screw elevator-cooperate with screw of various brands)

1. Ball screw diameter (16/20/25).
2. Ball screw lead (5/10/20/25).
3. The correct size is subject to 2D/3D.

规格表 Specifications

规格specification	D1(H6)	D2	D3	D4	D5	D6	A1	A2	A3	A4	A5	A6	A7
MB080AS-G4U	28/36	45	*依螺杆之尺寸而定			61.5	110	*依螺母尺寸而定		130	4-φ8.5	*依螺杆跨距而定	
MB110AS-G4U	40	65				61.5/65	142			170	4-φ8.5		

规格specification	A8	A9	A10	A11	A12	A13	A14
MB080AS-G4U	*依螺杆跨距而定				120	145	4-φ8.5
MB110AS-G4U					142	170	4-φ8.5

MB-G2-BST 2轴螺杆升降机型式

MB-G2-BST 2-AXIS SCREW LIFT TYPE

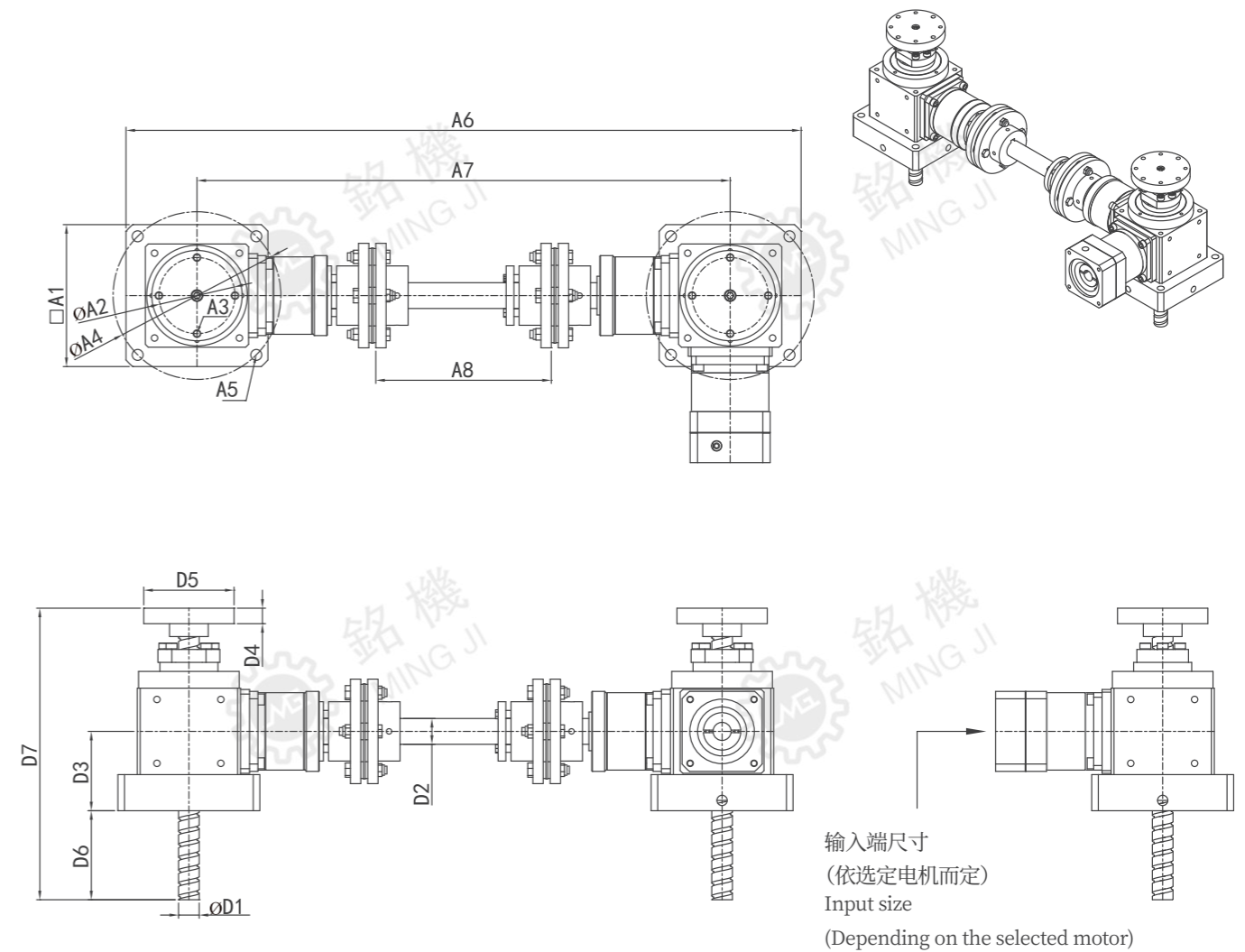

P.S: 2轴螺杆升降机

1. 滚珠螺杆直径(16/20/25)。
2. 滚珠螺杆导程(5/10/20/25)。
3. 订制品: 追加伸缩护管(套)
4. 正确尺寸依2D/3D为准。

P.S: 2-axis screw lift

1. Ball screw diameter (16/20/25).
2. Ball screw lead (5/10/20/25).
3. Customized products: additional telescopic protective tube (set)
4. The correct size is subject to 2D/3D.

规格表 Specifications

规格specification	D1	D2	D3	D4	D5	D6	D7	A1	A2	A3	A4	A5	A6	A7	A8
MB080AS-G2	16/20	20/25	61.5	12	70	螺杆有效长度	总长	110	59	4-M6	130	4-φ8.5	*依客户选定之跨距而定		
MB110AS-G2	25	20/30	61.5/65	23	90			142	74	4-M10	170	4-φ8.5			

MB-G4U-A-BST 4轴螺杆升降机型式

MB-G4U-A-BST 4-AXIS SCREW LIFT TYPE

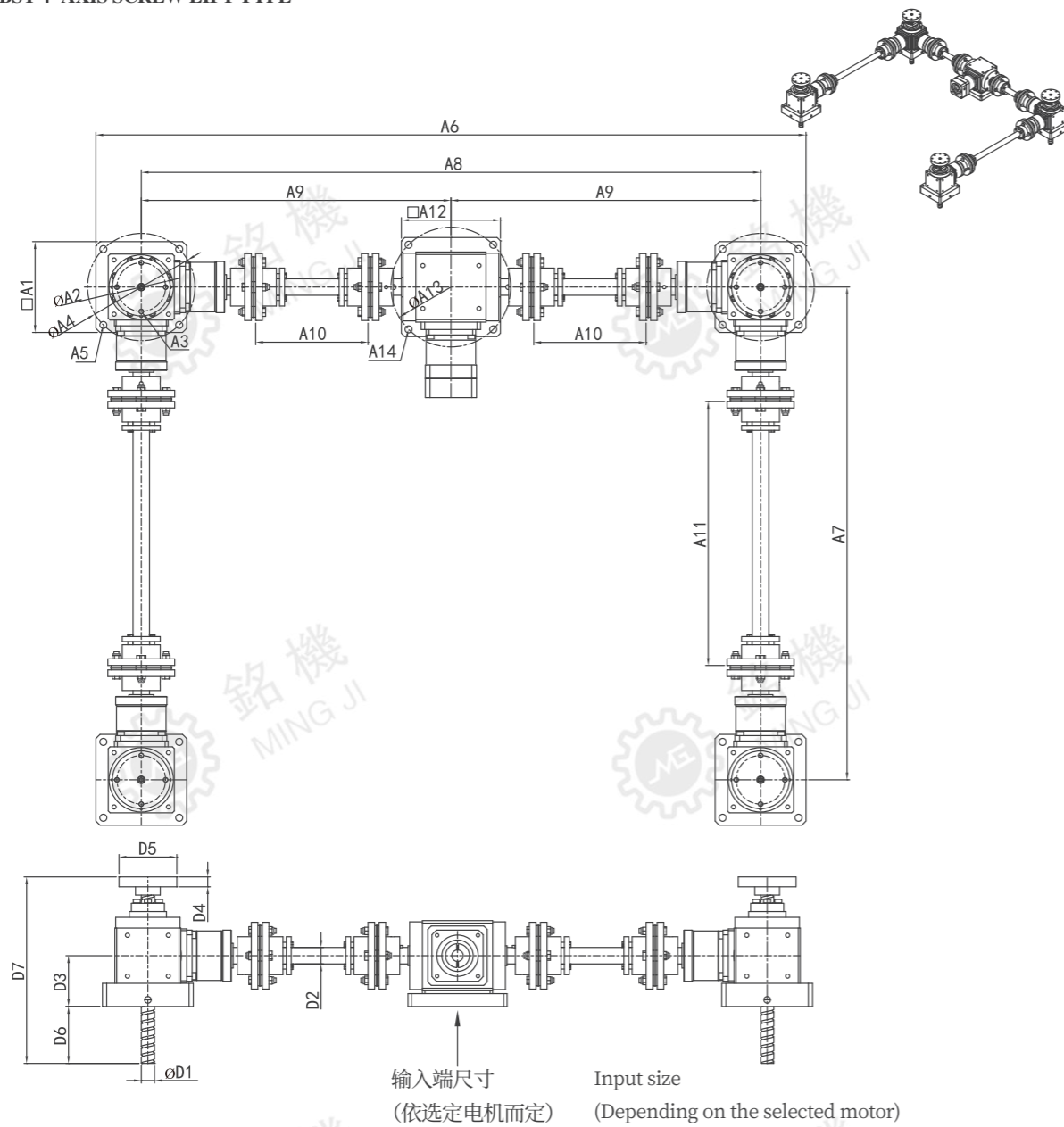

P.S: 4轴螺杆升降机
 1. 滚珠螺杆直径 (16/20/25)。
 2. 滚珠螺杆导程 (5/10/20/25)。
 3. 订制品: 追加伸缩护管(套)
 4. 正确尺寸依2D/3D为准。

P.S: 4-axis screw lift
 1. Ball screw diameter (16/20/25).
 2. Ball screw lead (5/10/20/25).
 3. Customized products: additional telescopic protective tube (set)
 4. The correct size is subject to 2D/3D.

规格表 Specifications

规格specification	D1	D2	D3	D4	D5	D6	D7	A1	A2	A3	A4	A5
MB080AS-G4U	16/20	20/25	61.5	12	70	螺杆有效长度	总长	110	59	4-M6	130	4-φ8.5
MB110AS-G4U	25	25/30	61.5/65	23	90			142	74	4-M10	170	4-φ8.5

规格specification	A6	A7	A8	D9	D10	D11	D12	D13	D14	
MB080AS-G4U	*依客户选定之跨距而定						120	145	4-φ8.5	
MB110AS-G4U	*依客户选定之跨距而定						142	170	4-φ8.5	

MB-G2-CR 2轴2点式中空轴型式

MB-G2-CR 2-AXIS 2-POINT HOLLOW SHAFT TYPE

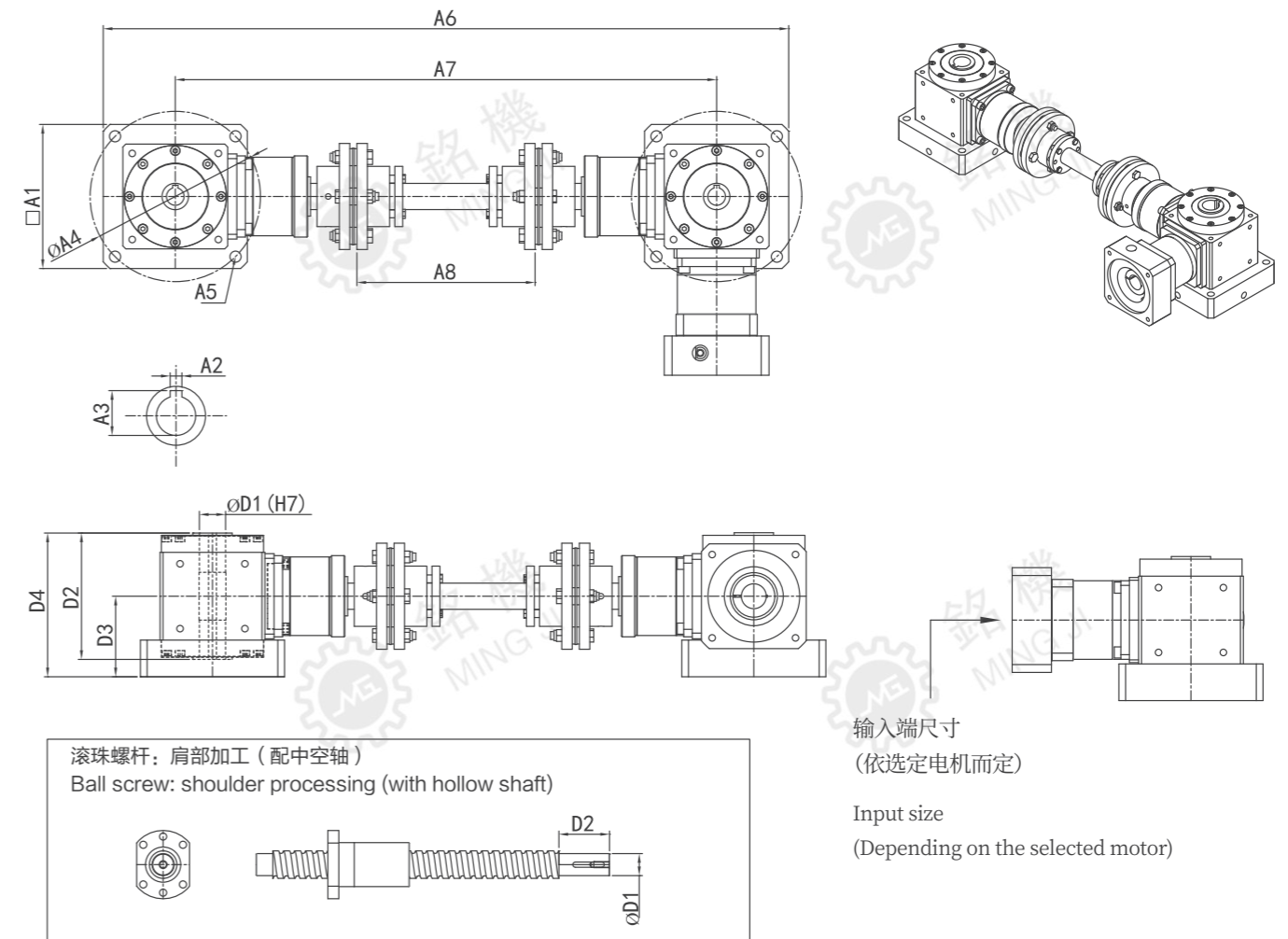

P.S: (2轴2点式升降机-中空轴)
 1. 滚珠螺杆直径 (16/20/25/32/40/50)。
 2. 滚珠螺杆导程 (5/10/20/25/30/32/40/50)。
 3. 正确尺寸依2D/3D为准。

P.S: (2-axis 2-point elevator-hollow shaft)
 1. Ball screw diameter (16/20/25/32/40/50).
 2. Ball screw lead (5/10/20/25/30/32/40/50).
 3. The correct size is subject to 2D/3D.

规格表 Specifications

规格specification	D1	D2	D3	D4	A1	A2	A3	A4	A5	A6	A7	A8
MB080AS-G2	12~20	96	61.5	109.75	12~20	*依实际螺杆肩部加工而定		130	4-φ8.5	*依客户选定之跨距而定		
MB110AS-G2	20~30	124	61.5/65	123.5	2030			170	4-φ8.5			
MB135AS-G2	32~40	146	94	158	3240			215	4-φ8.5			

MB系列 MB SERIES

MB-G4U-A-CR 4轴4点(中空轴)型式

MB-G4U-A-CR 4 AXIS 4 POINTS (HOLLOW SHAFT) TYPE

325/326

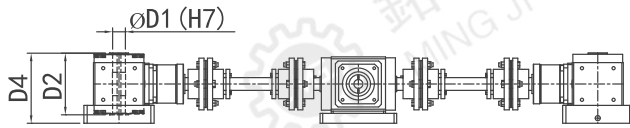
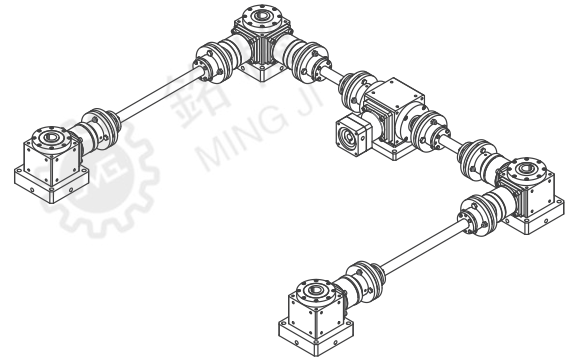
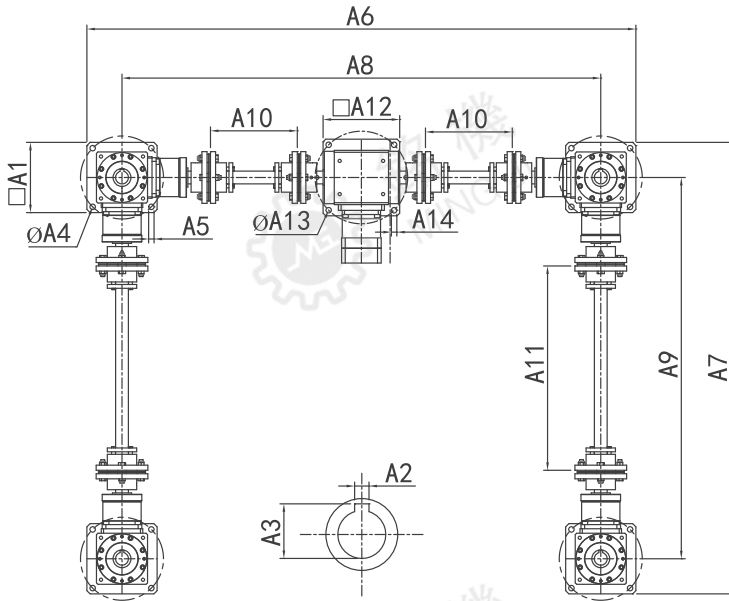

输入端尺寸
(依选定电机而定)
Input size
(Depending on the selected motor)



滚珠螺杆：肩部加工（配中空轴）
Ball screw: shoulder processing (with hollow shaft)

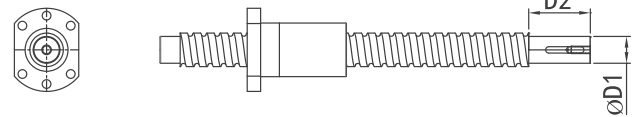

P.S: (4轴4点式升降机-中空轴)

1. 滚珠螺杆直径(16/20/25/32/40/50)。
2. 滚珠螺杆导程(5/10/20/25/30/32/40/50)。
3. 正确尺寸依2D/3D为准。

P.S: (4-axis 4-point elevator-hollow shaft)

1. Ball screw diameter (16/20/25/32/40/50).
2. Ball screw lead (5/10/20/25/30/32/40/50).
3. The correct size is subject to 2D/3D.

规格表 Specifications

规格specification	D1	D2	D3	D4	A1	A2	A3	A4	A5	A6~A11	A12	A13	A14
MB080AS-G4	12~20	96	61.5	109.75	110	*依实际螺杆 肩部加工而定		130	4-φ8.5	*依客户选定 之跨距而定	120	130	4-φ8.5
MB110AS-G4	20~30	124	61.5/65	123.5	142			170	4-φ8.5		142	170	4-φ8.5
MB135AS-G4	32~40	146	94	158	180			215	4-φ8.5		180	215	4-φ8.5